

REV	DESCRIPTION	DATE

## NOTES

**MATERIAL** (ABS) FLAME RETARDANT UL94 VO MATERIAL WITH BRASS INSERTS IN CORNER POSTS.  
(STYRENE) IS NON-FLAME RETARDANT WITHOUT BRASS INSERTS.

**PARTS** (ABS) VERSION MACHINE SCREWS M3-0.5 x 10mm.  
REPLACEMENT PN 1591MS100 (100 / BAG). (STYRENE)  
VERSION SELF TAPPING #4 x 0.5",  
REPLACEMENT PN 1591TS100 (100 / BAG).

**COLORS** (ABS) BLACK, & GRAY, (STYRENE) GRAY ONLY.

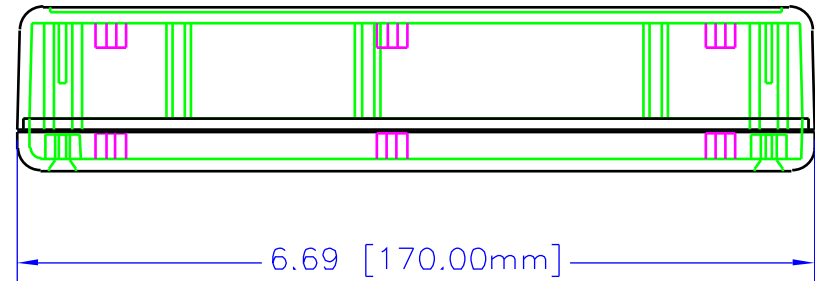
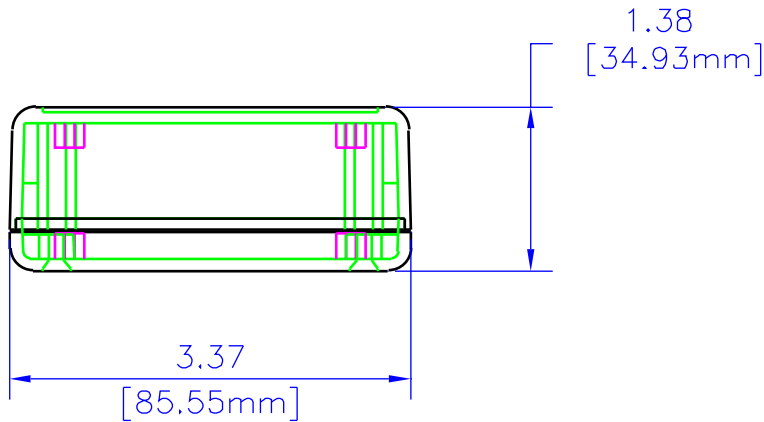
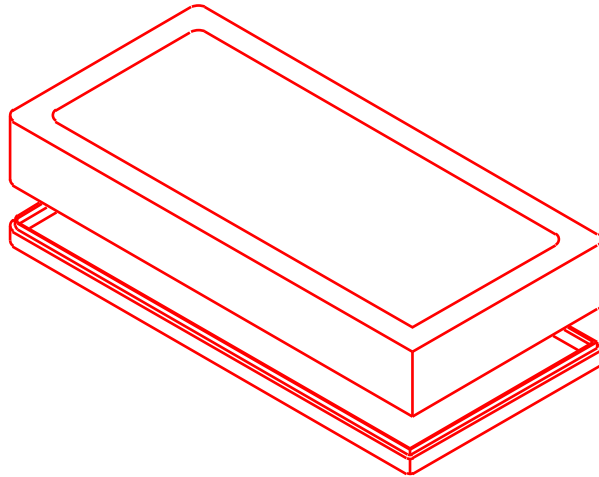

# ASSEMBLED

UNLESS OTHERWISE SPECIFIED  
DIMENSIONS ARE IN INCHES

F +/- .1  
XX +/- .02  
XXX +/- .010  
DITS +/- .005  
ANGLES +/- .5 DEG

**NOTICE**  
HAMMOND CLAIMS PROPRIETARY RIGHTS TO  
THE MATERIAL ON THIS DRAWING. IT IS  
INTENDED TO BE USED AS A REFERENCE FOR  
ENGINEERING INFORMATION ONLY. THIS  
INFORMATION MAY NOT BE USED TO  
MANUFACTURE PRODUCT WITHOUT WRITER  
PERMISSION FROM HAMMOND MANUFACTURING.



**HAMMOND  
MANUFACTURING**

WEB: [WWW.HAMMONDMFG.COM](http://WWW.HAMMONDMFG.COM)

TITLE  
**HAMMOND 1599 SERIES  
PLASTIC ENCLOSURE**

DRAWN BY MJM DATE 08/16/01  
SCALE PAGE 1 OF 3  
PART NUMBER  
**1599EBAT**

# NOTES

BATTERY LID IS REMOVED  
IN ALL VIEWS

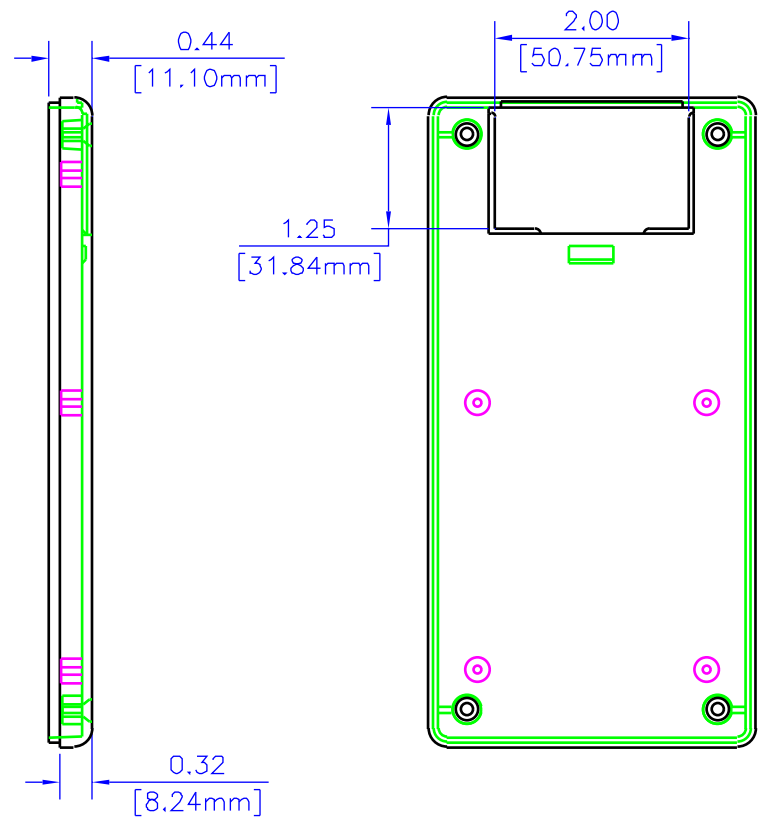
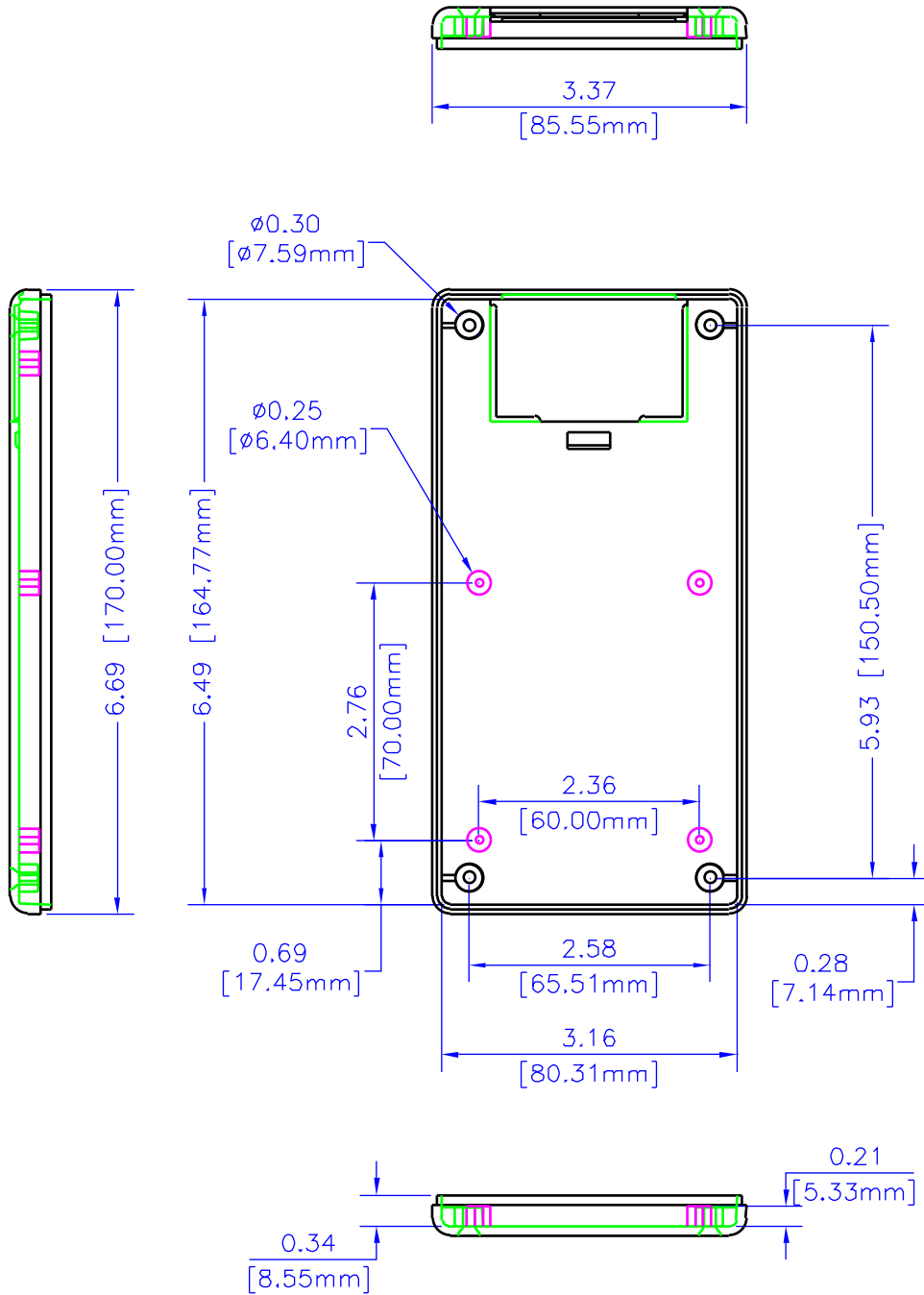

# LID

UNLESS OTHERWISE SPECIFIED  
DIMENSIONS ARE IN INCHES  
 F ±.01  
 XX ±.02  
 XXX ±.010  
 SLITS ±.005  
 ANGLES ±.5 DEG  
 TOLERANCES UNLESS OTHERWISE SPECIFIED TO THE MATERIAL ON THIS DRAWING. IT IS INTENDED TO BE USED AS A REFERENCE FOR ENGINEERING INFORMATION ONLY. THIS INFORMATION MAY NOT BE USED TO MANUFACTURE PRODUCT WITHOUT WRITTEN PERMISSION FROM HAMMOND MANUFACTURING.



**HAMMOND  
MANUFACTURING**

WEB: [WWW.HAMMONDMFG.COM](http://WWW.HAMMONDMFG.COM)

TITLE		HAMMOND 1599 SERIES PLASTIC ENCLOSURE	
DRAWN BY	MJM	DATE	08/16/01
SCALE		PAGE	5 OF 3
PART NUMBER		1599EBAT	

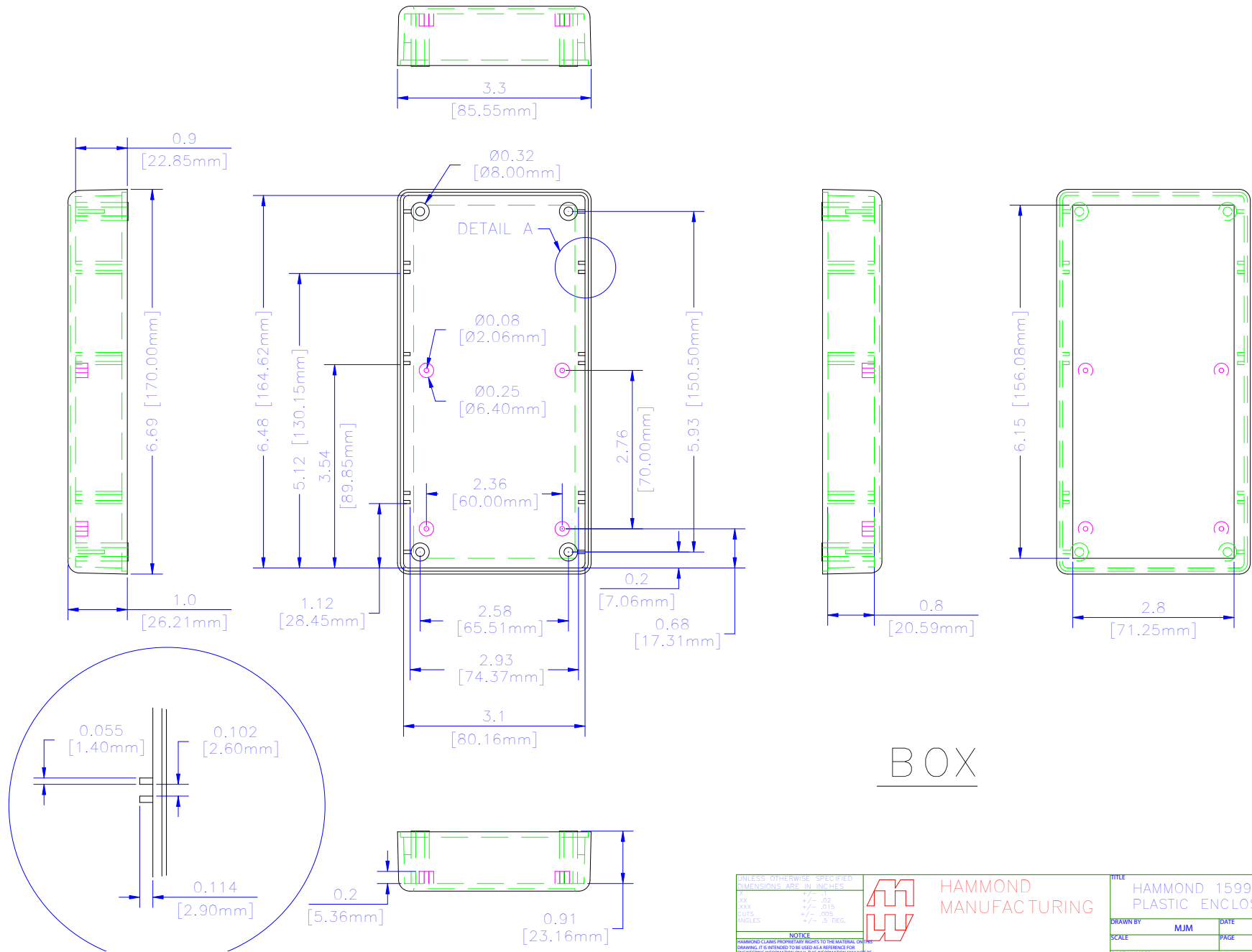

BOX

UNLESS OTHERWISE SPECIFIED  
DIMENSIONS ARE IN INCHES

XXX	+/- .01
XXXX	+/- .015
FIFTS	+/- .005
ANGLES	+/- .5 DEC.

**NOTICE**  
HAMMOND CLAIMS PROPRIETARY RIGHTS TO THE MATERIAL ON THIS DRAWING. IT IS INTENDED TO BE USED AS A REFERENCE FOR ENGINEERING INFORMATION ONLY. THE INFORMATION MAY NOT BE USED TO MANUFACTURE PRODUCTS WITHOUT WRITTEN PERMISSION FROM HAMMOND MANUFACTURING.

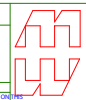

HAMMOND  
MANUFACTURING

WEB: WWW.HAMMONDMFG.COM

TITLE HAMMOND 1599 SERIES PLASTIC ENCLOSURE	
DRAWN BY MJM	DATE 08/16/01
SCALE	PAGE 2 OF 3
PART NUMBER 1599EBAT	